

1. HEAT SEAL REGULATOR IN PLASTIC BAG, AND PACKAGE REGULATOR AND INSTRUCTIONS IN BOX.

PRINT 0056-1215  
SHIPPER LABEL AS SHOWN:



DATE CODE PER SPEC. 0092-0005  
UPC-A BARCODE

COUNTRY OF ORIGIN INFORMATION

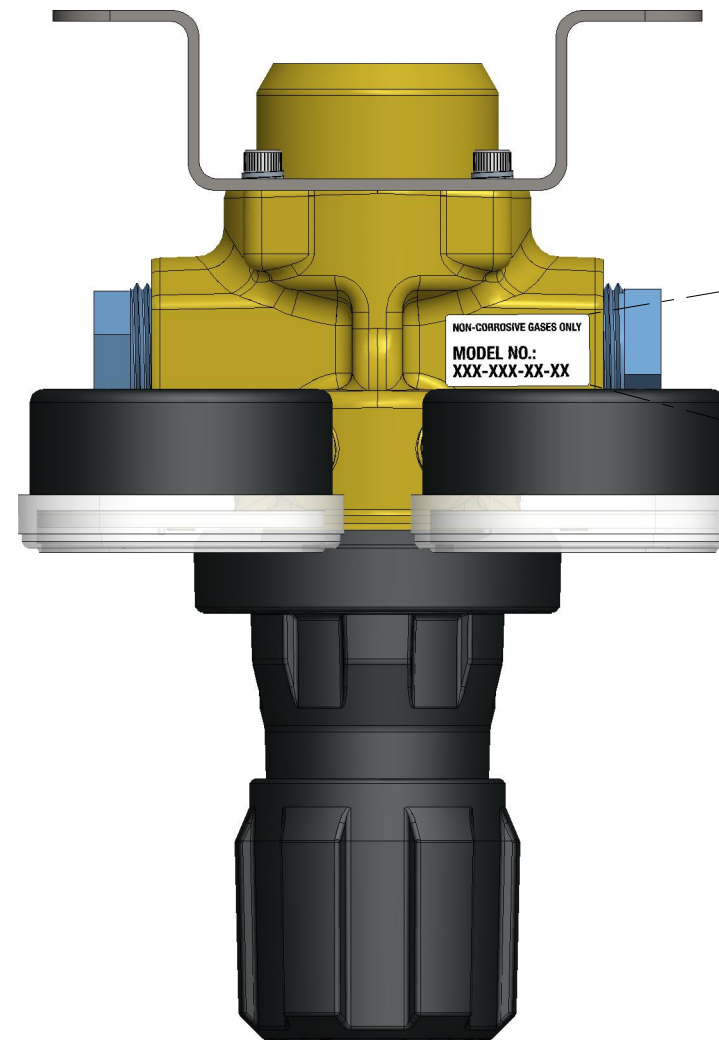
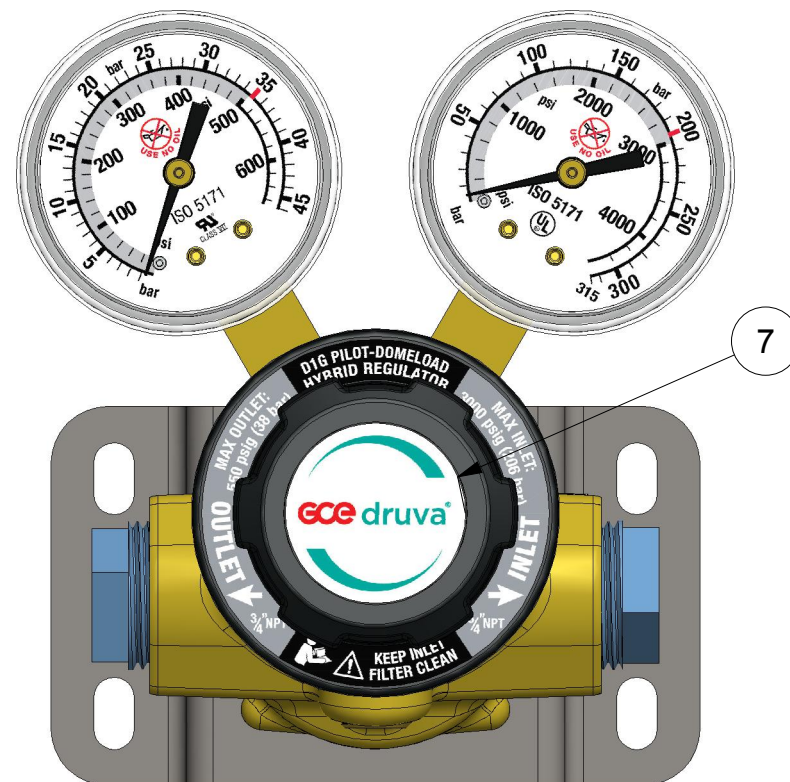

PRINT 0707-1223 LABEL AND APPLY AS SHOWN:



ITEM	PART NUMBER	DESCRIPTION	QTY
8	0782-4419	D1G DOME REGULATOR, BASE ASSM	1
7	0707-1716	DECAL GCEdruva 1.25 DIA	1
6	0707-1223	LABEL BLANK	1
5	0058-0739	FOAM PILLOW	1
4	0058-0330	BOX	1
3	0058-0098	BAG, "CLEANED FOR OXYGEN SERVICE"	1
2	0056-1215	LABEL BLANK 4-1/8 x 2-1/2	1
1	0056-0901	INSTRUCTIONS	1

THIS DOCUMENT IS CONFIDENTIAL, AND CONTAINS CONFIDENTIAL AND PROPRIETARY INFORMATION OF ESAB WELDING & CUTTING PRODUCTS, OR OF ONE OF ITS SUBSIDIARY OR AFFILIATE COMPANIES (COLLECTIVELY, "ESAB®") THAT SHALL NOT BE COPIED OR REPRODUCED IN ANY FORM, OR USED AND/OR DISCLOSED TO OTHERS, WITHOUT PRIOR WRITTEN PERMISSION. © ESAB® ALL RIGHTS RESERVED.

UNLESS OTHERWISE SPECIFIED		ESAB WELDING & CUTTING PRODUCTS		TITLE	
- KEY FEATURE CRITICAL TO QUALITY (XXX) - PRODUCT ASSEMBLY AND ALL INSTRUCTIONAL NOTES, PROCEDURES AND SPECIFICATIONS ARE CRITICAL TO QUALITY (CTQ). - ALL DIMENSIONS IN INCHES - DIMENSIONS ±.010 - ANGLES ±2°		2800 Airport Road Denton, Texas 76207 USA		<b>D1G-550-12F-12F REG GCEdruva</b> GCEdruva BRANDED	
DO NOT SCALE DRAWING THIRD ANGLE PROJECTION Unless otherwise specified, all material used must comply with the current EU RoHS Directive, EU REACH Directive, and the Dodd-Frank Act Conflict Minerals requirements.		DRAWN BY RAB	DESIGN APPROVAL RAB	ECN RELEASE DATE August 19, 2019 1:34:47 PM GMT	
		MATERIAL SEE BILL OF MATERIALS		DOCUMENT STATUS Pre-Released	
		FINISH -		SIZE A	SHEET(S) 1 OF 1
				PART NUMBER 0782-4426	REV AA